

How to Safely Package a Sample for Shipping to TVMDL

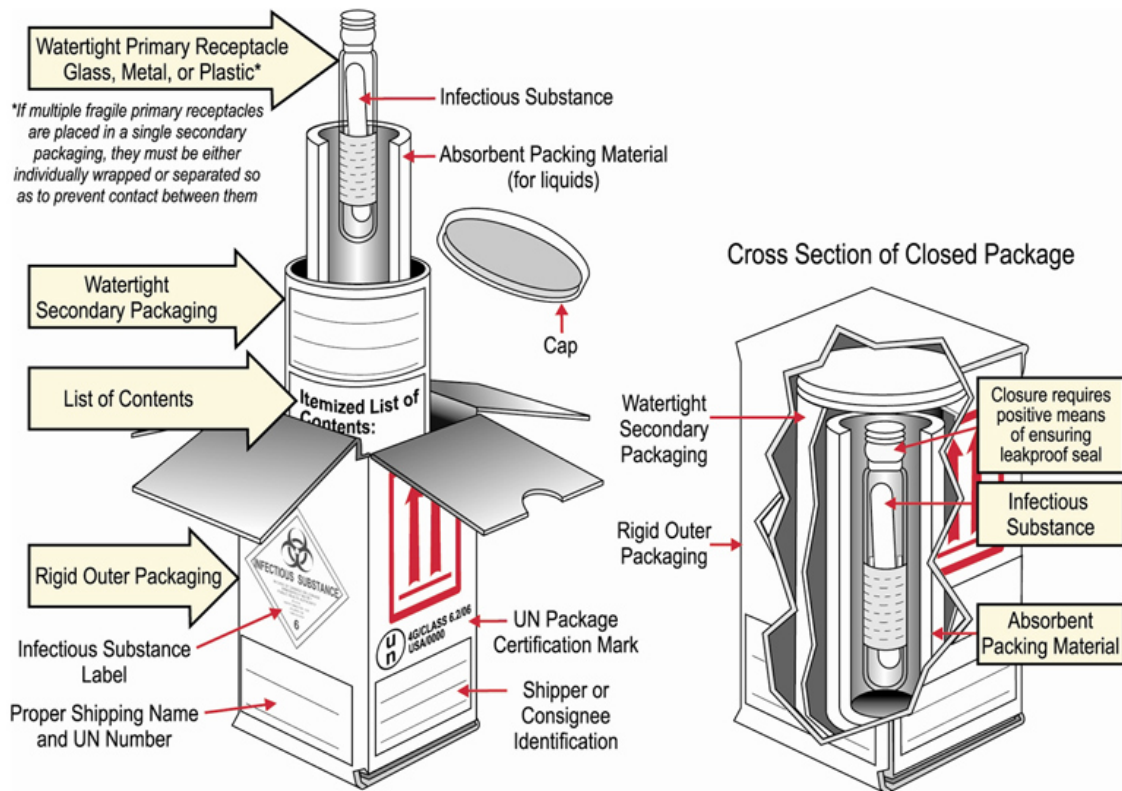

This illustration shows how to properly package a Category B infectious substance.
Source: Center for Disease Control and Prevention

There are four steps to safely preparing a sample to send to the Texas A&M Veterinary Medical Diagnostic Laboratory: classify your sample, package your sample, mark or label the package, and document your shipment.

Step 1: Classify Your Sample

Category A infectious substance: Infectious substance in a form that, when exposure to it occurs, is capable of causing permanent disability, life threatening, or fatal disease in otherwise healthy humans or animals (IATA Dangerous Goods Regulations §3.6.2.2.2.1). For examples of Category A infectious substances, visit <http://tvmdl.tamu.edu/library/files/Table36D.pdf>. If you suspect you have a Category A infectious substance, please contact us at (979) 845-3414 or (888) 646-5623.

Category B infectious substance: An infectious substance that is transported in a form that, when exposure to it occurs is NOT capable of causing permanent disability, life-threatening or fatal disease in otherwise healthy humans or animals. TVMDL recommends all suspect infectious disease shipments be classified and shipped as a Biological Substance Category B.

Exempt animal specimen: Specimen collected directly from animals for research, diagnosis, disease treatment and prevention which there is a minimal likelihood that pathogens are present. Examples include: chemistry panel, CBC, endocrine testing, surveillance serology, export or movement testing, and vaccine titer).

Step 2: Package Your Sample

The packaging must consist of three components: a primary receptacle, secondary packaging, and a rigid outer packaging. Primary receptacles must be packed in secondary packaging in such a way that, under normal conditions of transport, they cannot break, be punctured, or leak their contents into the secondary packaging.

Secondary packaging must be secured in outer packaging with suitable cushioning material. Any leakage of the contents must not compromise the integrity of the cushioning material or of the outer packaging.

An itemized list of contents is enclosed between the secondary and outer packaging. A properly completed TVMDL submission form may be used for this purpose.

At least one surface of the outer packaging has a minimum dimension of 100 mm x 100 mm (4 inches x 4 inches).

Ice packs, dry ice or other refrigerant, if needed, may be placed around the secondary packaging, but must not compromise the paperwork or inner/outer containers upon melting, sweating, etc.

For Liquid Substances:

- The primary receptacle is leak-proof;
- The secondary packaging is leak-proof;
- Absorbent material is in sufficient quantity to absorb the entire contents placed between the primary and secondary packaging;
- If multiple fragile primary receptacles are placed in a single secondary packaging, they must be either individually wrapped or separated so as to prevent contact between them.

For Solid Substances:

- The primary receptacle is sift-proof;
- The secondary packaging is sift-proof;
- If multiple fragile primary receptacles are placed in a single secondary packaging, they must be either individually wrapped or separated so as to prevent contact between them.

Step 3. Mark or Label Your Package

The outer packaging must have the following information:

- The name, address, and telephone number of a responsible person on the waybill or on the package.
- The shipper's and consignee's addresses.
- For "Biological Substance, Category B", this label must be present in letters at least 6 mm high must be marked on the outer package adjacent to a diamond-shaped UN3373 label.
- For "Exempt Animal Specimen", this label must be present on the outer package in letters at least 6 mm high. NOTE: this classification still requires proper packaging (see Step 2 above).
- If packaged with dry ice, a Class 9 label, including UN1845 label, and net weight.

Step 4. Document Your Shipment.

- A Shipper's Declaration is NOT required.
- Air Waybill — If applicable, the text "Biological Substance, Category B" and "UN 3373" should be documented on the waybill.
- If shipping with dry ice, UN 1845 and net weight of dry ice must be indicated.

Got questions about shipping? For answers, call any of TVMDL's four locations.